

CATALOG NUMBER: E - SRNOOF70

FOR ONE 70 WATT, S62 HIGH PRESSURE SODIUM LAMP

60 HZ REACTOR-HPF

INPUT VOLTS	120		
CIRCUIT TYPE	R - HPF		
POWER FACTOR	90 %		
REGULATION			
Line Volts	+/- 5 %		
Lamp Watts	WITHIN TRAPEZOID		
LINE CURRENT (Amps)			
Operating	0.75		
Open Circuit	1.45		
Starting	0.72		
UL TEMPERATURE RATINGS			
Insulation Class	H (180° C)		
Coil Temperature Code	1029 A		
MIN. AMBIENT STARTING TEMP	-40° F or -40° C		
NOM. OPEN CIRCUIT VOLTAGE	120		
INPUT VOLTAGE AT LAMP DROPOUT	95		
INPUT WATTS	81		
RECOMMENDED FUSE (AMPS)	5		
CORE AND COIL			
Dimension (A)	1.30"		
Dimension (B)	2.50"		
Weight (lbs)	2.70		
Lead lengths	12"		
CAPACITOR REQUIREMENT			
Microfarads	28		
Volts (min)	120		
60 HZ TEST PROCEDURES			
HIGH POTENTIAL TEST (Volts)			
1 minute	2000		
1 second	2500		
Open Circuit Voltage Test (Volts)	114 - 126		
Short-Circuit Current Test (Amps)			
Secondary Current	1.8 - 2.06		
Input Current	1.20		
	1.37		

2 5/8 X 2 3/16 CORE

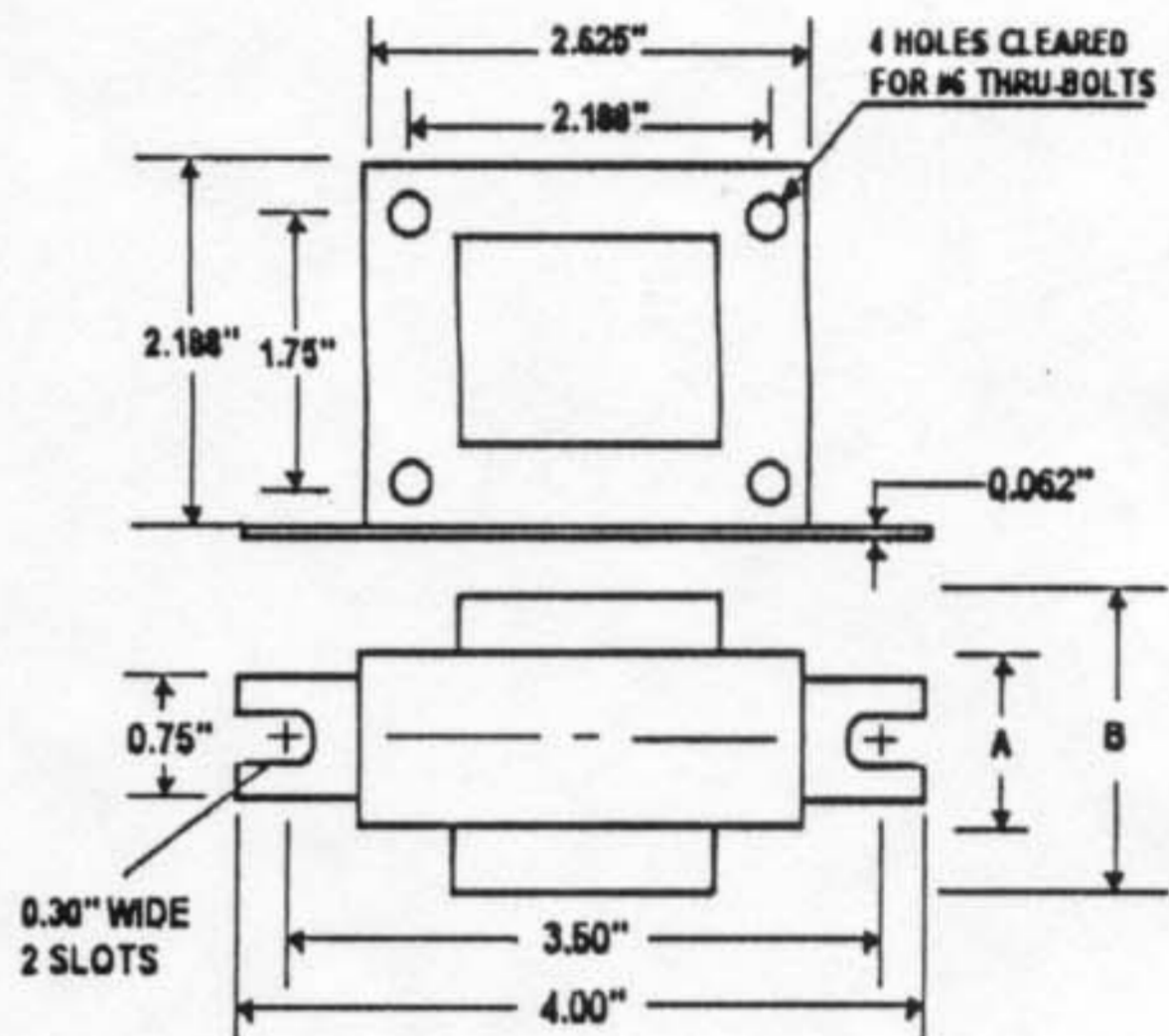

WIRING DIAGRAM

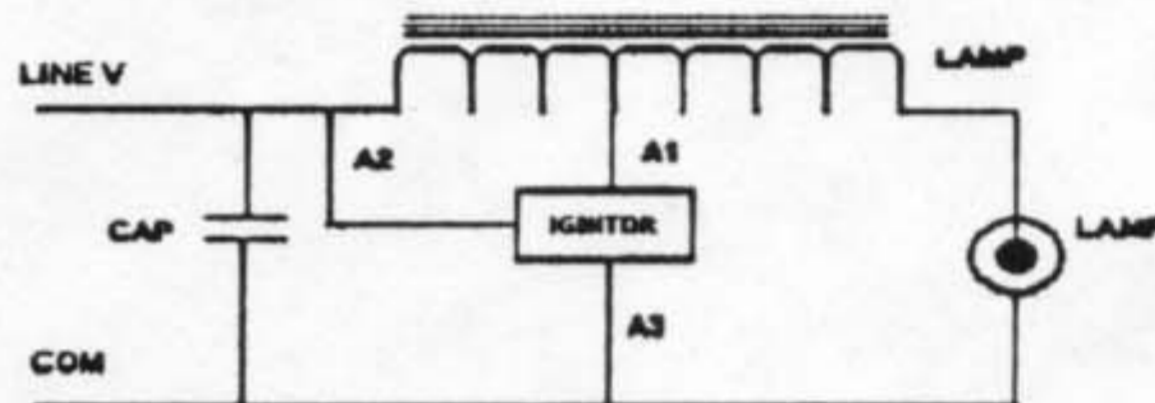

CAPACITOR

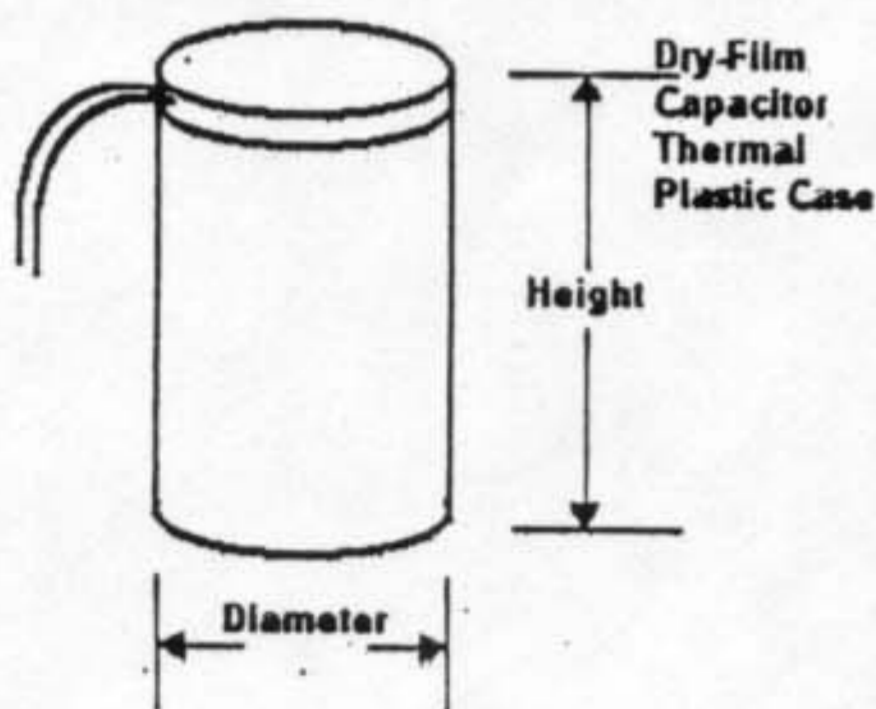

Temp. Rating 110° C
Height: 3.92 in
Diameter: 1.60 in

IGNITOR 37-63-AS-11.1N

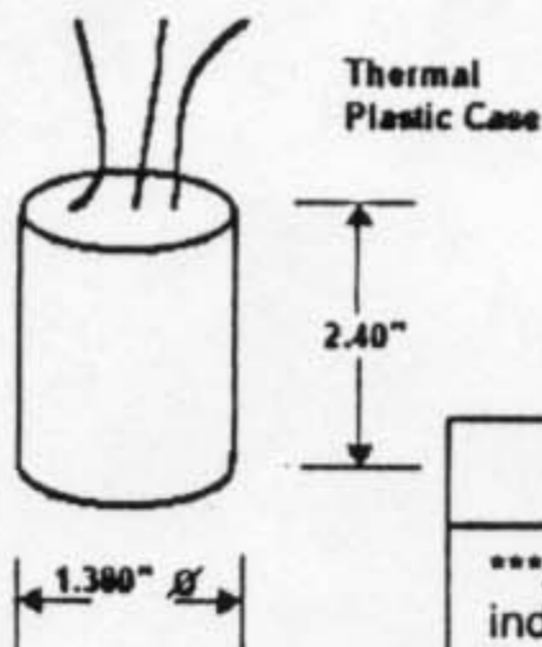

Temp. Rating 110° C
Ballast to Lamp Distance (BTL) = 3 feet



Ordering Information

***Add proper suffix to catalog number when ordering as indicated below:
No suffix = Core and Coil and Ignitor Only
B= Core and Coil, Ignitor and Welded Bracket
C= Core and Coil, Ignitor and Capacitor
BC= Core and Coil, Ignitor, Capacitor and Welded Bracket

Data is based upon tests performed by Industrias Sola Basic in a controlled environment and representative of relative performance. Actual performance can vary depending on operating conditions. Specifications are subject to change without notice

10/18/99

Made in Mexico by Industrias Sola Basic S.A. de C.V.